

4-Line Bidirectional Symmetrical (BiSy) ESD-Protection Diode in SOT-23-5L

Features

- SOT-23-5L package
- 4-line ESD-protection
- Working range ± 5.5 V
- Low leakage current $< 0.1 \mu\text{A}$
- Low load capacitance $C_D = 16$ pF
- ESD-protection acc. IEC 61000-4-2
 - ± 20 kV contact discharge
 - ± 30 kV air discharge
- Pin plating tin (e3)
- Compliant to RoHS directive 2002/95/EC and in accordance to WEEE 2002/96/EC



RoHS
COMPLIANT
GREEN
[5-2008]**

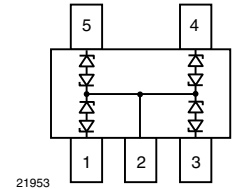
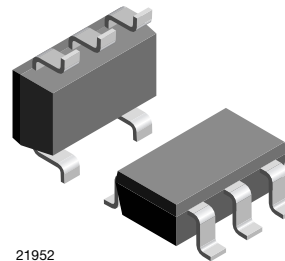

Marking (example only)

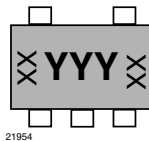

YYY = Type code (see table below)
XX = Date code

Ordering Information

Device name	Ordering code	Taped units per reel (8 mm tape on 7" reel)	Minimum order quantity
VCUT05A4-05S	VCUT05A4-05S-G-08	3000	15 000

Package Data

Device name	Package name	Type code	Weight	Molding compound flammability rating	Moisture sensitivity level	Soldering conditions
VCUT05A4-05S	SOT-23-5L	5A4	15.5 mg	UL 94 V-0	MSL level 1 (according J-STD-020)	260 °C/10 s at terminals

Absolute Maximum Ratings

Parameter	Test conditions	Symbol	Value	Unit
Peak pulse current	Acc. IEC 61000-4-5, 8/20 μs /single shot	I_{PPM}	3.5	A
Peak pulse power	Pin 1 to pin 2, acc. IEC 61000-4-5, 8/20 μs /single shot	P_{PP}	56	W
ESD immunity	Contact discharge acc. IEC61000-4-2; 10 pulses	V_{ESD}	± 20	kV
	Air discharge acc. IEC61000-4-2; 10 pulses		± 30	
Operating temperature	Junction temperature	T_j	- 40 to + 85	°C

** Please see document "Vishay Material Category Policy": <http://www.vishay.com/doc?99902>

Cut the spikes with VCUT05A4-05S:

The **VCUT05A4-05S** is a **Bidirectional** and **Symmetrical (BiSy)** ESD-protection device which clamps positive and negative overvoltage transients to ground. Connected between the signal or data line and the ground the **VCUT05A4-05S** offers a high isolation (low leakage current, low capacitance) within the specified working range.

Electrical Characteristics ($T_{amb} = 25\text{ }^{\circ}\text{C}$, unless otherwise specified)

VCUT05A4-05S

Parameter	Test conditions/remarks	Symbol	Min.	Typ.	Max.	Unit
Protection paths	Number of lines which can be protected	N_{lines}			4	lines
Reverse stand-off voltage	at $I = 0.1\text{ }\mu\text{A}$	V_{RWM}	5.5			V
Reverse current	at $V = 5.5\text{ V}$	I_R			0.1	μA
Reverse breakdown voltage	at $I = 1\text{ mA}$	V_{BR}	7	7.5		V
Reverse clamping voltage	at $I_{PP} = 1\text{ A}$	V_C			12	V
	at $I_{PP} = I_{PPM} = 3.5\text{ A}$	V_C			16	V
Capacitance	at $V = 0\text{ V}$; $f = 1\text{ MHz}$	C_D		16	20	pF

Typical Characteristics ($T_{amb} = 25\text{ }^{\circ}\text{C}$, unless otherwise specified)

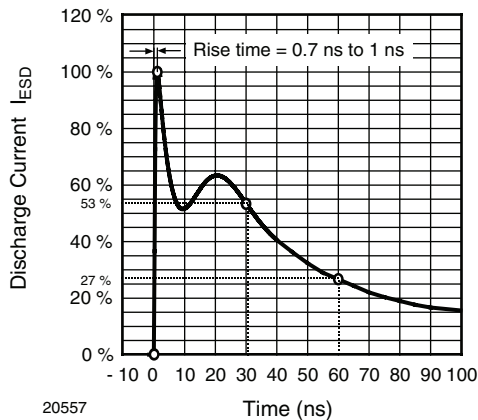

Figure 1. ESD Discharge Current Wave Form
acc. IEC 61000-4-2 (330 Ω /150 pF)

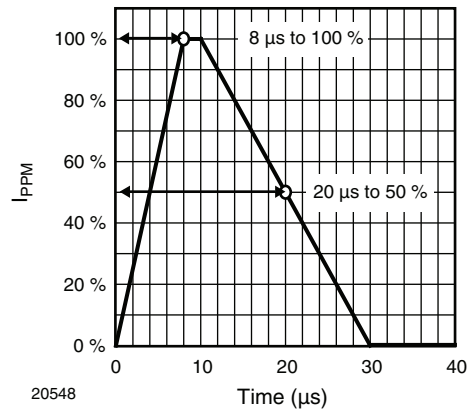

Figure 2. 8/20 μs Peak Pulse Current Wave Form
acc. IEC 61000-4-5

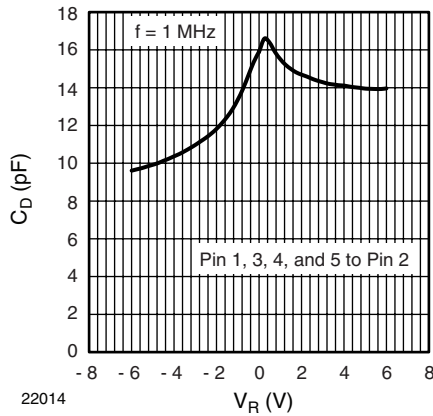

Figure 3. Typical Capacitance C_D vs. Reverse Voltage V_R

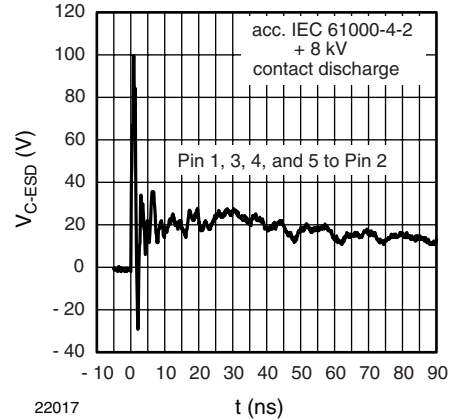

Figure 6. Typical Clamping Performance at +8 kV Contact Discharge (acc. IEC 61000-4-2)

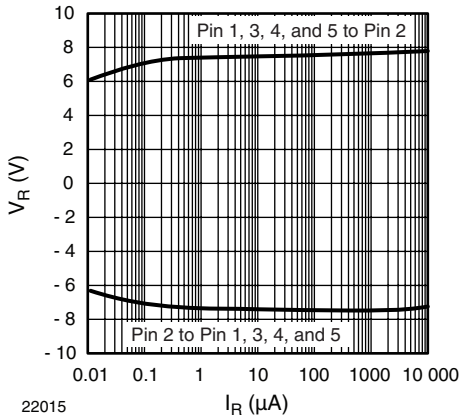

Figure 4. Typical Reverse Voltage V_R vs. Reverse Current I_R

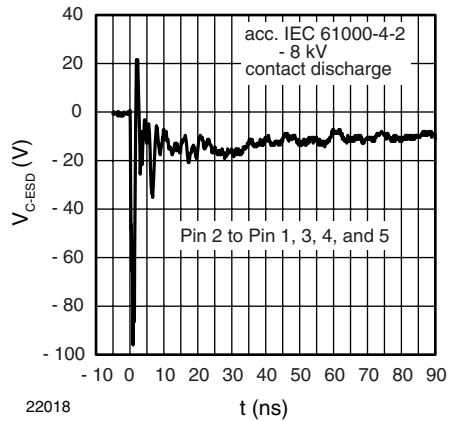

Figure 7. Typical Clamping Performance at -8 kV Contact Discharge (acc. IEC 61000-4-2)

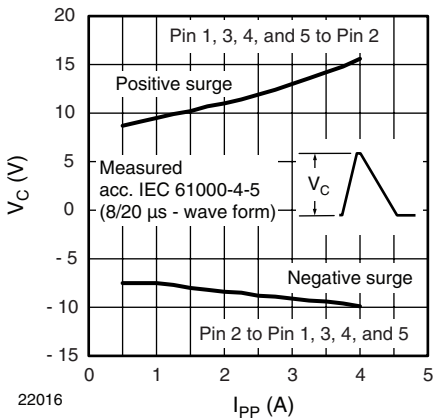

Figure 5. Typical Peak Clamping Voltage V_C vs. Peak Pulse Current I_{PP}

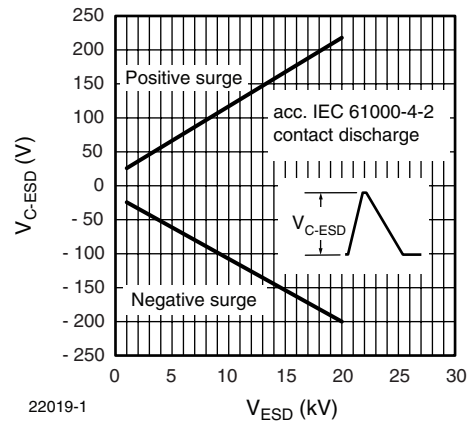
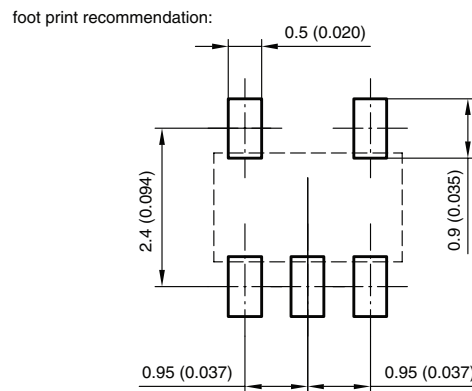
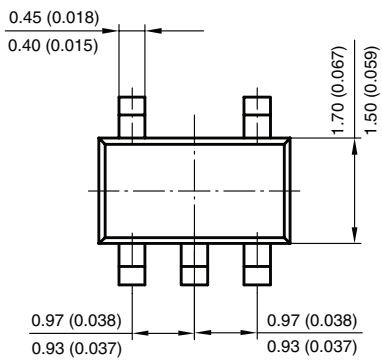
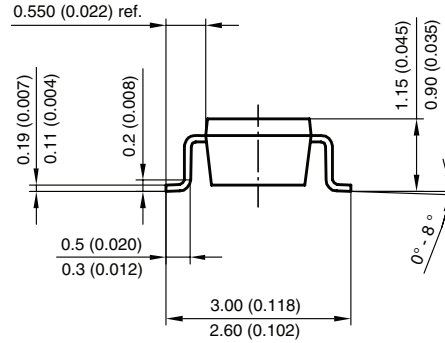
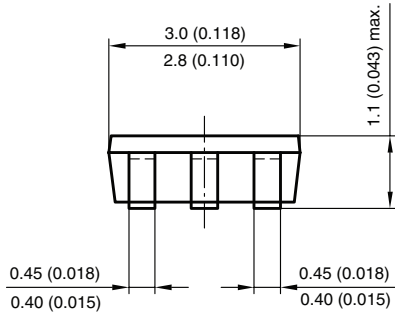

Figure 8. Typical Peak Clamping Voltage at ESD Contact Discharge (acc. IEC 61000-4-2)

Package Dimensions in millimeters (inches): SOT-23-5L



Document no.: S8-3929.01-001 (4)
 Rev. 1 - Date: 15.Jan.2010
 21955

Orientation in Blistertape

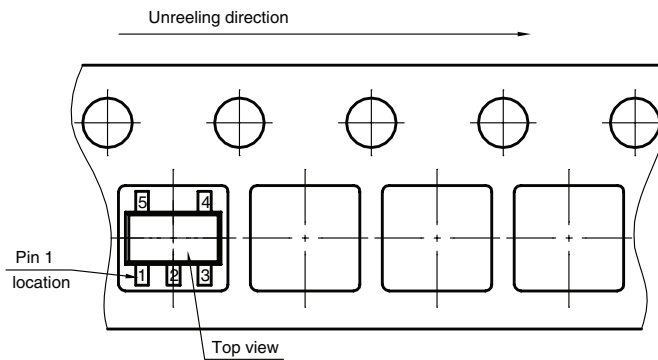

S8-V-3929.01-003 (4)
 Date: 23. 11. 2009
 22006



Disclaimer

All product specifications and data are subject to change without notice.

Vishay Intertechnology, Inc., its affiliates, agents, and employees, and all persons acting on its or their behalf (collectively, "Vishay"), disclaim any and all liability for any errors, inaccuracies or incompleteness contained herein or in any other disclosure relating to any product.

Vishay disclaims any and all liability arising out of the use or application of any product described herein or of any information provided herein to the maximum extent permitted by law. The product specifications do not expand or otherwise modify Vishay's terms and conditions of purchase, including but not limited to the warranty expressed therein, which apply to these products.

No license, express or implied, by estoppel or otherwise, to any intellectual property rights is granted by this document or by any conduct of Vishay.

The products shown herein are not designed for use in medical, life-saving, or life-sustaining applications unless otherwise expressly indicated. Customers using or selling Vishay products not expressly indicated for use in such applications do so entirely at their own risk and agree to fully indemnify Vishay for any damages arising or resulting from such use or sale. Please contact authorized Vishay personnel to obtain written terms and conditions regarding products designed for such applications.

Product names and markings noted herein may be trademarks of their respective owners.